

## Installation, Operation and Maintenance Manual

Please read and save these instructions for future reference. Read carefully before attempting to assemble, install, operate or maintain the product described. Protect yourself and others by observing all safety information. Failure to comply with these instructions will result in voiding of the product warranty and may result in personal injury and/or property damage.



C#5005978



Intertek

Number	Description
1	Flooring Systems
2	Wood Truss
3	Air Ducts
4	CRD-3XXWT assembly
5	Mounting Angle
6	Gypsum Board
7	Grille
8	Finishing System (not shown)

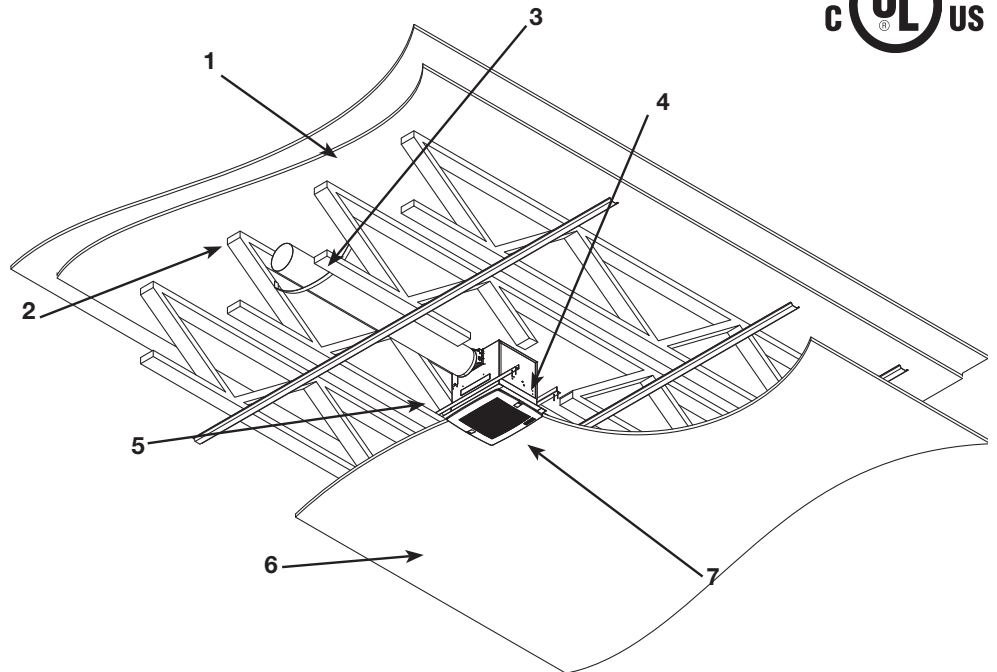

Isometric view of CRD-310WT in wood truss system

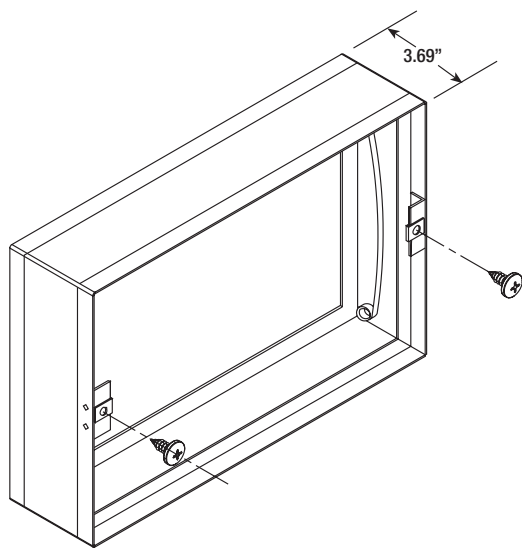

Isometric view of a CRD-3XX series damper.

Wires to ceiling fan

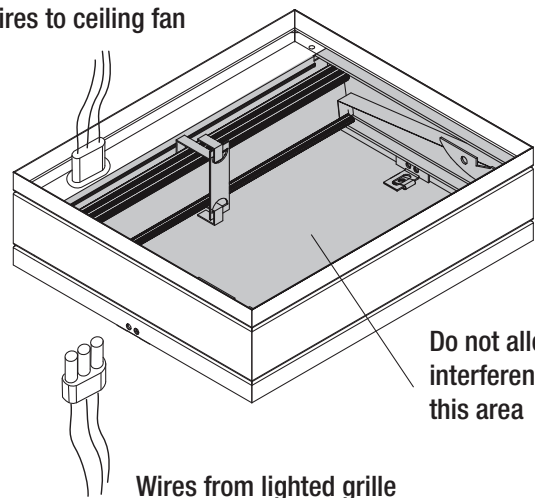

Do not allow interference in this area

Wires from lighted grille

Isometric view for wiring the CRD-3XX series damper to the lighted grille and ceiling fan.

This manual is the property of the owner and is required for future maintenance. Please leave it with the owner when the jobs is complete.

## Table of Contents

General Information .....	2
Plaster Flange Application.....	3
Damper Installation to a SP Fan .....	4
Installation .....	5-7
• ETL - Wood Construction .....	5
• UL/cUL - 1 Hour Combustible Floor/Ceiling .	6
• UL/cUL - 3 Hour Non -Combustible Floor/ Ceiling.....	7
Maintenance.....	8
Troubleshooting.....	8

## Receiving and Handling

Upon receiving dampers, check for both obvious and hidden damage. If damage is found, record all necessary information on the bill of lading and file a claim with the final carrier. Check to be sure that all parts of the shipment, including accessories, are accounted for.

Dampers must be kept dry and clean. Indoor storage and protection from dirt, dust and the weather is highly recommended. Do not store at temperatures in excess of 100°F (38°C).

## Safety Warning

Improper installation, adjustment, alteration, service or maintenance can cause property damage, injury or death. Read the installation, operating, and maintenance instructions thoroughly before installing or servicing this equipment.

## General Information

**“UL CLASSIFIED (see complete marking on product)”**

**“UL CLASSIFIED to Canadian safety standards (see complete marking on product)”**

Standard 555C (Listing #R13446)

These installation instructions show recommended installation procedures. These or other installation methods may be followed subject to the approval of the authority having jurisdiction.

Model CRD-310, 320, 350, 360, 310L, 320L, 310WT, CRD-320WT, and 700 are specific sizes of Greenheck’s model

DFD-350 dampers equipped with hardware to facilitate installation with Greenheck model SP ceiling exhaust fans.

The CRD-3xx(L, WT) series and CRD-700 dampers are classified to function as a heat barrier in air handling penetrations through fire resistive membrane ceilings. They are intended to maintain the fire resistive integrity of the ceiling. They can only be installed in conjunction with the SP fan models shown and cannot be installed alone.

**NOTE:** Motors for fan models used in conjunction with CRD shall be equipped with thermal cut-off fuse control.

## Plaster Flange Application

**Note: The plaster flange is required when the damper is installed in a combustible floor/ceiling assembly.**

When the damper is installed in a non-combustible ceiling/floor assembly, the plaster flange is not required and can be discarded. When unpacking the flange kit from the damper, remove all tape residue from the damper and plaster flange.

When the plaster flange is required, the flange assembly must be attached to the damper as follows.

1. Unfold the plaster flange assembly that is supplied. Wrap the assembly around the damper in the orientation shown in **Figure 1**. Connect the open ends of the flange together.
2. Align the edge of the plaster flange with the edge of the damper frame. When using the CRD-320WT, apply a ¼ in. bead of 3M Fire Barrier Sealant CP 25WB+ between the damper frame and plaster flange assembly. Clamp the flange to the damper frame.
3. Using the flange holes as a guide, secure the flange to the damper frame using the supplied fasteners. Install fasteners within 1½ inches (38mm) from each corner first, then at or near the center of each damper side. Install a fastener on both sides of the grille mounting tabs. Be careful to not strip out the damper frame material while installing the fasteners.
4. When using the CRD-320WT, apply a ¼ in. bead of 3M Fire Barrier Sealant CP 25WB+ on the top side of the plaster flange assembly. Seal any gaps between the damper, plaster flange assembly and the drywall.

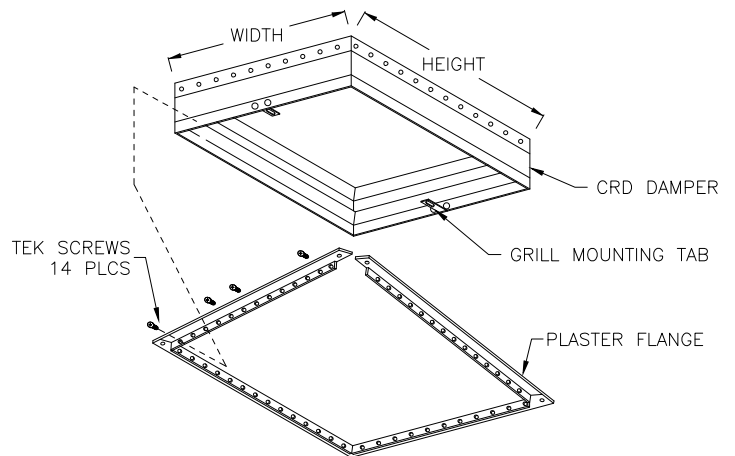

**Figure 1: CRD damper with plaster flange**

## Damper Installation to a SP Fan

- 1. General:** The fan/damper assemblies described in these instructions, when installed as shown, provide appropriate protection for air inlet or outlet penetrations in the ceiling membrane of floor/ceiling and roof/ceiling assemblies with fire resistance ratings of up to 3 hours.
- 2. System Components:** All system components (ducts, duct drops, hanger wires, sleeves, and diffuser pan) must be constructed of steel. The diffuser core may be non-ferrous. Grilles may be non-metallic. Flexible duct (if used) must be Class 1 or Class 0 type, bearing the UL listing mark. Maximum length of flex duct shall not exceed 14 feet. The installations and air devices shown in these instructions illustrate general arrangement only. Installations must also incorporate any specific requirements in the FRD (UL Fire Resistance Directory). Note that both “Design Information - General” and individual ceiling/floor or ceiling/roof design listings apply.
- 3. Ceiling Penetrations:** Ceiling penetration should be located within ceiling tiles, panels, or gypsum without necessitating cuts in the ceiling suspension

main runners, cross tees, or trusses. If required, a maximum of one runner or cross tee may be cut to enable proper damper location and installation. Each cut end shall be supported by a minimum 12 SWG vertical hanger wire. a ½ in. clearance must be maintained between the air inlet/outlet and the cut end of the runner or cross tee. Cutting of wood trusses in combustible ceiling designs is not permitted.

- 4. Connections:** Connections must be made using #8 sheet metal screws, ⅜ in. tubular steel rivets, tack or spot welds. Use a minimum of one connection per side for rectangular or square dampers and three equally spaced connections for round dampers. Space fasteners a maximum of 6 in. apart. Any W or H dimension larger than 12 in. requires a minimum of two connections per side. All screws or rivet attachments shall be placed a minimum of ⅜ in from the edge of the damper frame, duct drop, diffuser, or grille frame. When making connections, the ceiling radiation damper may slide over the neck or inside the neck of the diffuser, grille, or inlet/outlet device.

SP Fan Size	CRD Model						
	UL Classified		ETL (Warnock Hersey) Listed	“D”	“E”	Width (in.)	Height (in.)
	1 Hour Com- bustible	3 Hour Non- Combustible		(See Figure 4)			
SP-B50, SP-B70, SP-B80, SP-B90, SP-B110, SP-B110ES, SP-B150, SP-B200, SP-L50, SP-L80	CRD-320WT	CRD-320 CRD-320L CRD-320 WT	CRD-320 CRD-320L	4½	15⅝	14⅜	12¼
SP-A50, SP-A70, SP-A90, SP-A110, SP-A125, SP-A190, SP-A50-90-VG, SP-A90-130-VG	CRD-310WT	CRD-310 CRD-310L CRD-310-WT	CRD-310 CRD-310L	5½	14⅝	13½	11⅞
SP-A250, SP-A290, SP-A390, SP-A390-VG, SP-A200	-	CRD-320 CRD-320L	CRD-320 CRD-320L	6¾	15½	14⅜	12¼
SP-A410, SP-A510, SP-A510-VG SP-A710, SP-A710-VG, SP-A780	-	CRD-350	CRD-350	9¼	19⅝	18⅞	14⅞
SP-A900, SP-A1050 SP-A1050-VG, SP-A1300, SP-A1410, SP-A1550		CRD-360	CRD-360	9¼	25⅝	24⅞	14⅞
SP-A700, SP-A700-VG		CRD-700	--	9¼	25⅝	24⅞	12¼

# ETL Installation - 1 Hour Combustible Floor/Ceiling Assemblies

(formerly Warnock Hersey)

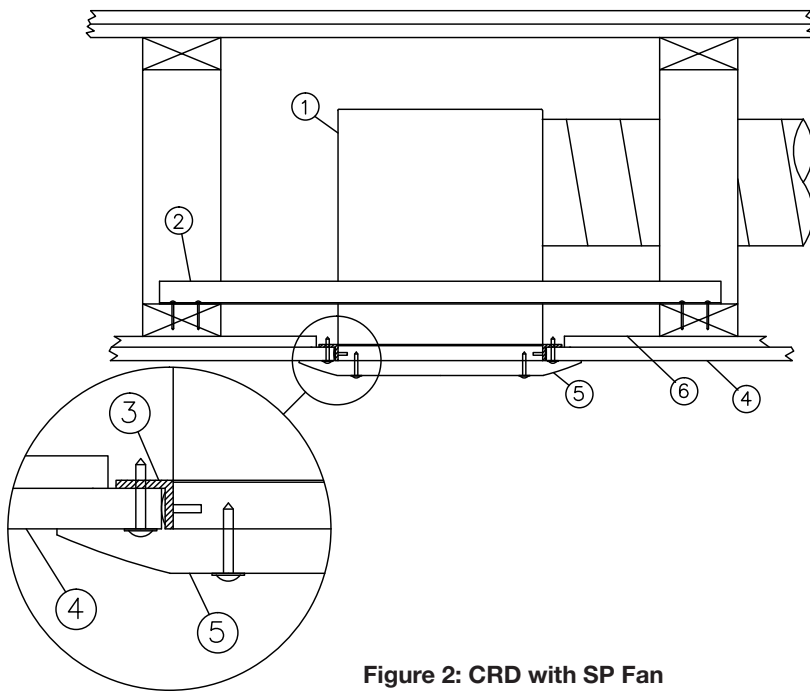

- 1: Fan/Damper Assembly
- 2: Mounting Angle
- 3: Plaster Flange
- 4: Gypsum Board
- 5: Grille
- 6: RC Channel

Figure 2: CRD with SP Fan

## Ceiling Exhaust Fan Installation

1. Fan/damper assemblies installed in combustible floor ceiling assemblies with gypsum board ceilings require the use of a plaster flange (**Item 3 in Figure 2**). A plaster flange kit, which comes with all of the necessary mounting hardware, is supplied with the unit.
2. The fan/damper assembly is to be attached to the trusses using 2 - 1 in. x 1 in. x 16 ga. (25mm x 25mm x 1.5mm) or 2 - 1¼ in. x 1 in. x 20 ga. (32mm x 25mm x 1mm) mounting angles. Attach mounting angles to the damper with a minimum of 2 - #8 screws or 5/32 in. (4mm) diameter steel rivets.

Note: Make sure the fasteners do not interfere with the damper operation.

3. Install the fan/damper assembly, with attached mounting angles, between the trusses as shown in **Figure 2** and attach mounting angles to the trusses using 4 - 1¼ in. long steel screws per mounting angle.
4. Run a minimum of 4 - 1 in. (25mm) long #6 screws through the gypsum board into the plaster flange as shown in **Figure 2**.

## Grille Installation

Mount grille to underside of ceiling radiation damper using #10 x ½ in. Phillips head stainless steel sheet metal screws provided with SP fan.

# UL/cUL Installation - 1 Hour Combustible Floor/Ceiling Assemblies

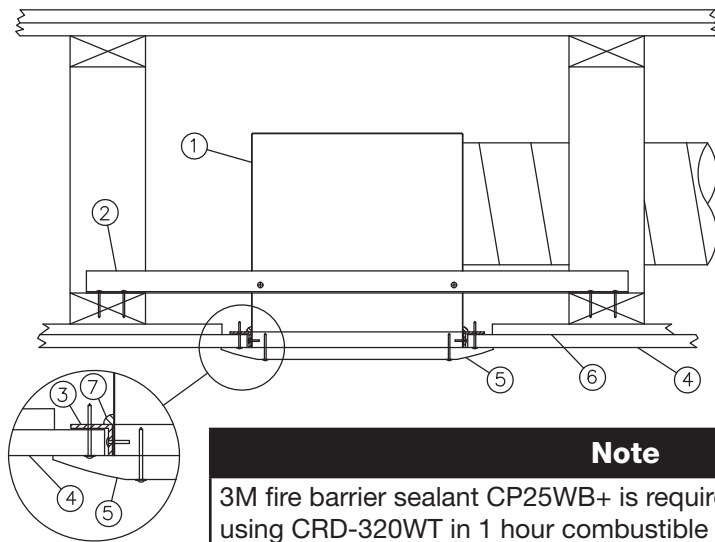

1. Fan/Damper assembly
2. Mounting angle
3. Plaster flange
4. Gypsum board
5. Grille
6. RC channel
7. 3M fire barrier sealant CP25WB+  
(Required with CRD-320WT, optional for all other CRD models)

**Note**

3M fire barrier sealant CP25WB+ is required to be applied when using CRD-320WT in 1 hour combustible floor/ceiling assemblies.

Figure 3: CRD with SP Fan

## Ceiling Exhaust Fan Installation

1. Fan/damper assemblies installed in combustible floor ceiling assemblies with gypsum board ceilings require the use of a plaster flange (**Figure 3, Item 3**). A plaster flange kit, which comes with all of the necessary mounting hardware, is supplied with the unit.

2. The fan/damper assembly is to be attached to the trusses using 2 - 1 in. x 1 in. x 16 ga. (25mm x 25mm x 1.5mm) or 2 - 1 1/4 in. x 1 in. x 20 ga. (32mm x 25mm x 1mm) mounting angles. Attach mounting angles to the damper with a minimum of 2 - #8 screws or 5/32 in. (4mm) diameter steel rivets.

Note: Make sure the fasteners do not interfere with the damper operation.

3. Install the fan/damper assembly, with attached mounting angles, between the trusses as shown in **Figure 3** and attach mounting angles to the trusses using 4 - 1 1/4 in. long steel screws per mounting angle.

4. Run a minimum of 8 - 1 in. (25mm) long #6 screws through the gypsum board into the plaster flange as shown in **Figure 3**.

## Grille Installation

Mount grille to underside of ceiling radiation damper using #10 x 1/2 in. Phillips head stainless steel sheet metal screws provided with SP fan.

These instructions describe the installation of a CRD-310WT and CRD-320WT in designs: L528, L546, L558, L562, L574, L576, L581, L583, L585, L592, M501, M503, M508, P533, P538, P545, P547, P548, P554, and P580 as detailed in the UL Fire Resistance Directory.

GA File No.	UL Design No.
FC 5012	M508
FC 5078	L558
FC 5101	L574, M508
FC 5119	L592
FC 5121	L528, L546, L574, M508
FC 5514.4	L585
FC 5515	L528
FC 5515.3	M503
FC 5516	L528
FC 5519	L574
FC 5521	L562
FC 5528	L528
RC 2603	P533
RC 2604	P554
RC 2606	P545
RC 2609	P538
RC 2612	P545, P554
GA = Gypsum Association Fire Resistance Manual 22 <sup>nd</sup> Edition	



# UL/cUL Installation - 3 Hour Non Combustible Floor/Ceiling Assemblies

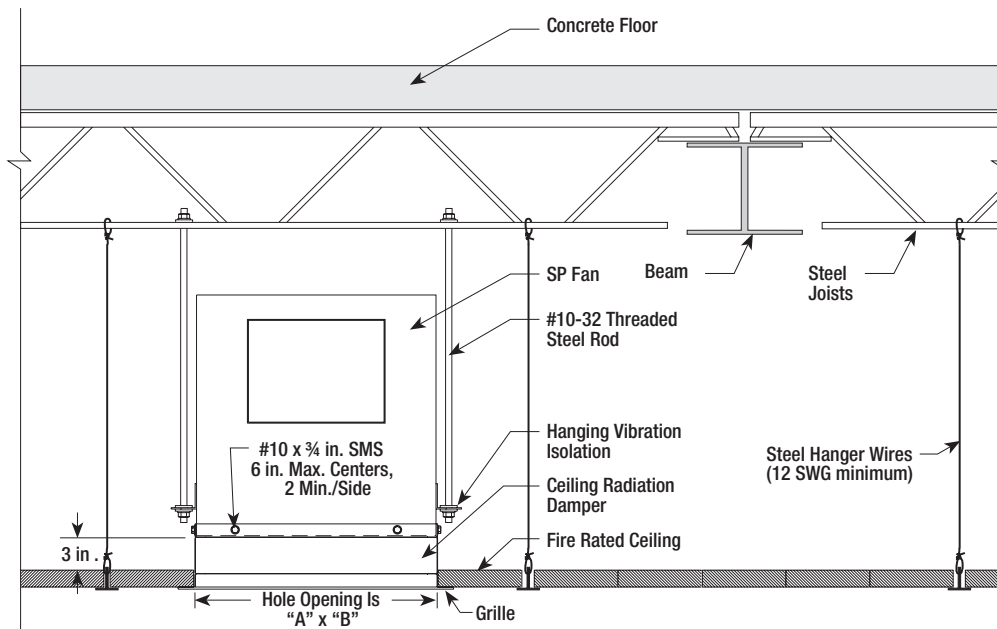

Figure 4

## Ceiling Exhaust Fan Support

The following two mounting methods may be used.

1. Suspend fan/damper assembly using #10-32 threaded steel rod as shown in **Figure 5**. Suspend from joists or cold rolled channels (do not suspend from beams). If vibration isolators are used, fender washers must have a larger outside diameter than the holes in the fan mounting angle.
2. Support fan/damper assembly using (2) minimum 16 ga. x 1½ in. steel channels with ¼ in. flanges. Suspend from joists or cold rolled channels (do not suspend from beams). Alternatively, bolt channels ends directly to joists or other cold rolled channels using minimum #10 bolts. See **Figure 6**.

Do NOT support fan/damper assembly by ceiling tile or ceiling grid (Tee) members when using with a suspended ceiling!

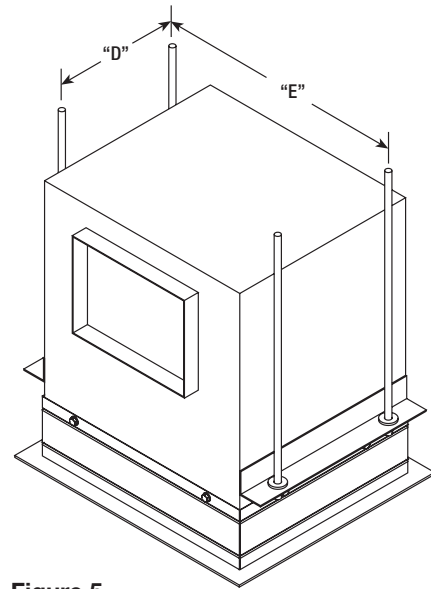

Figure 5

## Grille Installation

Mount grille to underside of ceiling radiation damper using 2 - #10 x ½ in. Phillips head stainless steel sheet metal screws provided with SP fan.

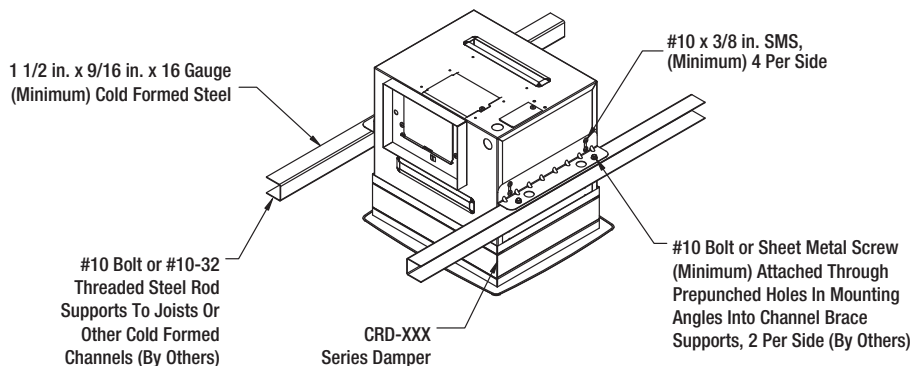

Figure 6

## Damper Maintenance

---

Dampers do not typically require maintenance as long as they are kept dry and clean. If cleaning is necessary, use mild detergents or solvents. If lubrication is desired for components such as axle bearings, jackshaft bearings and jamb seals, do not use oil-based lubricants or any other lubricants that attract contaminants such as dust.

## Damper Troubleshooting

---

The following is a possible cause and correction list for common concerns with the dampers.

Symptom	Possible Cause	Corrective Action
Damper does not fully open and/or close	Frame is 'racked' causing blades to bind on jamb seals	Adjust frame such that it is square and plumb
	Screws in damper linkage	Damper installed too far into wall. Move out to line as designated on damper label
	Contaminants on damper	Clean with a non-oil based solvent (see Damper Maintenance)
Link separated	Heat	Replace link

## Our Commitment

---

*As a result of our commitment to continuous improvement, Greenheck reserves the right to change specifications without notice.*

Product warranties can be found online at [Greenheck.com](http://Greenheck.com), either on the specific product page or in the literature section of the website at [Greenheck.com/Resources/Library/Literature](http://Greenheck.com/Resources/Library/Literature).

