

# Centrifugal Downblast Exhaust Fan, Model G-070, Direct Drive, 3-Speed, 115V, 1Ph, 179-374 CFM

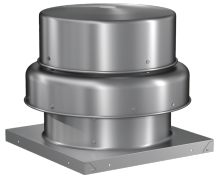

Model G, direct drive centrifugal roof exhaust fans provide the industry's best performance and durability for general clean air applications where air is discharged downward, toward the roof. Units feature the most advanced motor cooling of any fan in its class.

- 17 x 17 inch base with prepunched mounting holes for easy attachment to roof curb
- Speed controllable, with up to 30% turndown
- 13.5 x 13.5 inch recommended roof opening

### Certifications

AMCA Sound & Air  
High Wind and Hurricane  
Seismic  
UL/cUL 705

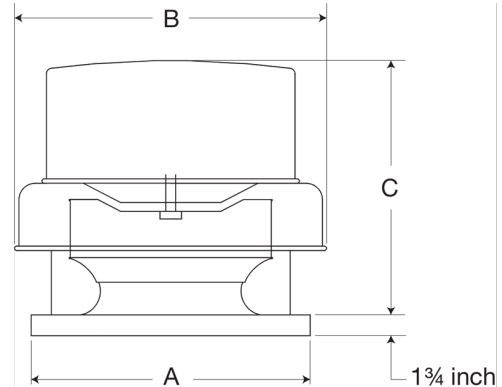

### Performance Characteristics

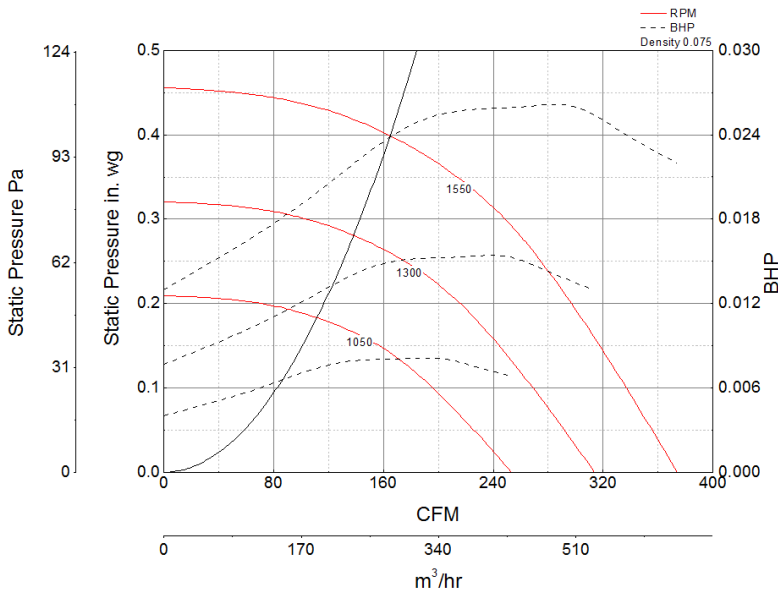

### Construction Features

Drive Type	Direct Drive
Impeller Type	Centrifugal Wheel
Impeller Material	Composite
Housing Material	Spun Aluminum
Certifications	AMCA Sound & Air
Certifications	High Wind and Hurricane
Certifications	Seismic
Certifications	UL/cUL 705
Speed Controllable	Yes
Required Accessory	Roof curbs for new installations

### Motor Information

Service Factor	1
Phase	1
Voltage	115
HP	1/30
Motor Enclosure	n/a
Motor Insulation	B
Thermal Protection	AutoOverload

### Air and Sound Performance

Motor HP	Max BHP	Max Fan RPM	Min Fan RPM	Ps (in. wg)	0	0.125	0.25	0.375
0.0333	0.03	1550	1050	CFM	374	327	274	190
				Sones	5.6	5.1	4.7	4.4



- Greenheck Fan Corporation certifies that the model shown herein is licensed to bear the AMCA Seal. The ratings shown are based on tests and procedures performed in accordance with AMCA Publication 211 and AMCA Publication 311 and comply with the requirements of the AMCA Certified Ratings Program.
- Performance certified is for installation type A: Free inlet, Free outlet.
- Power rating (BHP/kW) does not include transmission losses.
- Performance ratings include the effects of birdscreen.
- The sound ratings shown are loudness values in fan sones at 5 ft. (1.5 m) in a hemispherical free field calculated per AMCA Standard 301. Values shown are for installation type A: free inlet hemispherical sone levels.