

## Bathroom Exhaust Fan, Model SP-A70, 115V, 1Ph, 54-88 CFM



- Industry leading low sound levels
- ENERGY STAR rated
- Acoustic insulation absorbs sound ensuring quiet operation
- Spring loaded aluminum backdraft damper eliminates rattling
- External electrical access reduces installation time
- Speed controllable
- Designer grille included

### Certifications

AMCA Air &Sound  
UL/cUL 507

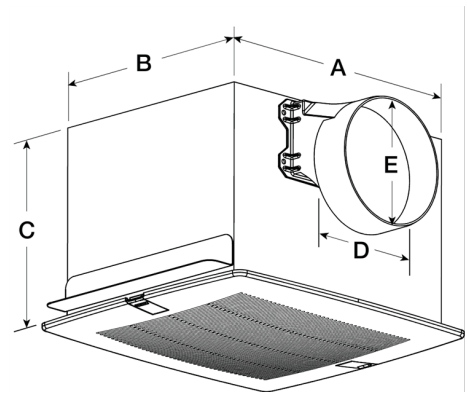

### Performance Characteristics

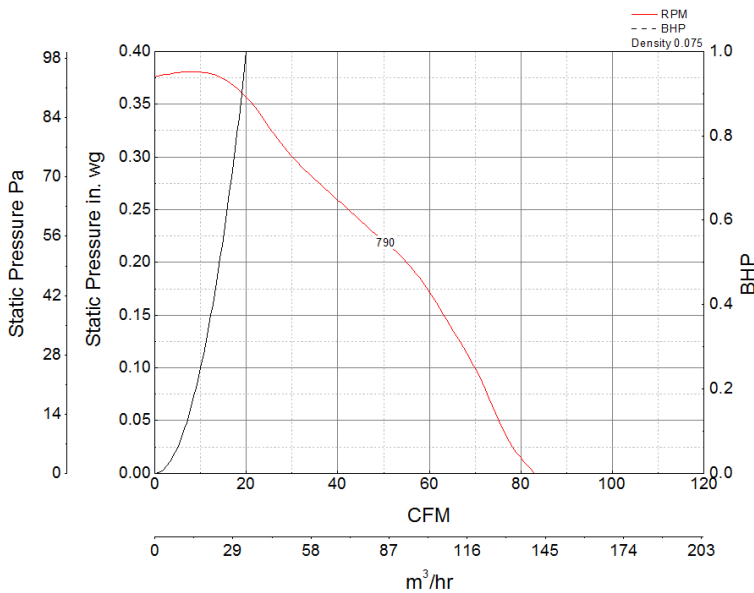

### Construction Features

Drive Type	Direct Drive
Impeller Type	Centrifugal Wheel
Impeller Material	Polypropylene
Housing Material	Galvanized Steel
Includes	Backdraft damper
Includes	Mounting brackets
Certifications	AMCA Air &Sound
Certifications	UL/cUL 507
Speed Controllable	Yes

### Motor Information

Service Factor	1
Phase	1
Voltage	115
Motor Enclosure	n/a
Motor Insulation	A
Thermal Protection	OneShot
Watts	1.36

### Air and Sound Performance

Watts	Max Fan RPM	Min Fan RPM	Ps (in. wg)	0	0.125	0.25
15.6	790	632	CFM	88	71	54
			Sones	<0.3	<0.3	<0.3