

**Centrifugal Upblast Exhaust Fan, Product # CUBE-140-10122GQD-DR2, 1728-3134 CFM**

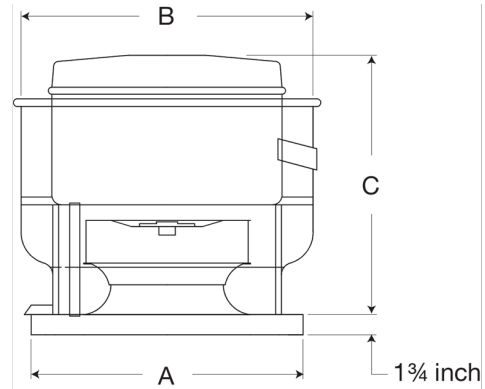

The CUBE is an aluminum exhaust fan specifically designed for roof or sidewall mounted applications where contaminated or grease laden exhaust air can be discharged directly upward, away from the roof or wall surface. The fans feature a one piece windband continuously welded to curb cap and double studed isolators for true vibration isolation.

- 22 x 22 inch base with prepunched mounting holes for easy attachment to roof curb
- 18.5 x 18.5 inch recommended roof opening
- Roof or wall mountable



**Certifications**

AMCA Sound & Air  
UL/cUL 705 Listed - Supplement SC - "Power Ventilators for Restaurant Exh. Appliances" (Formerly UL 762)

**Performance Characteristics**

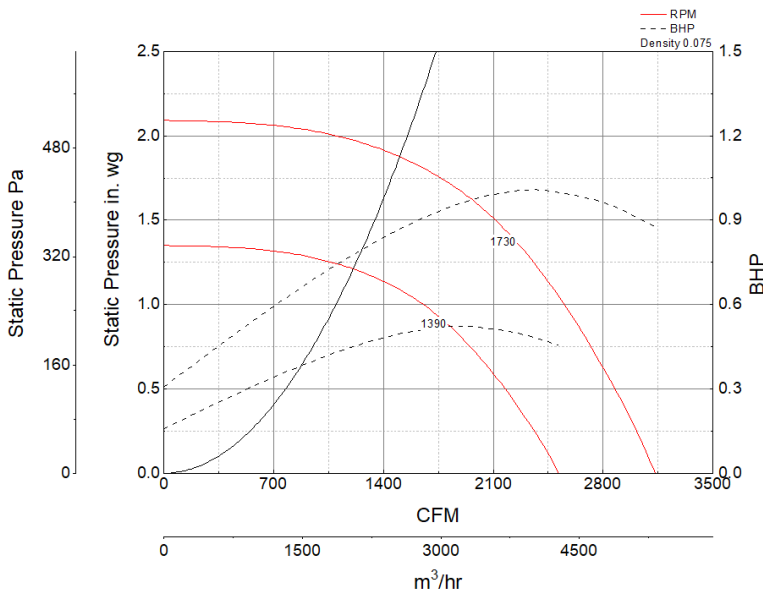

**Construction Features**

Drive Type	Belt Drive
Impeller Type	Centrifugal Wheel
Impeller Material	Aluminum
Housing Material	Spun Aluminum
Includes	Unassembled drive package
Certifications	AMCA Sound & Air
Certifications	UL/cUL 705 Listed - Supplement SC - "Power Ventilators for Restaurant Exh. Appliances" (Formerly UL 762)
Drive Package Description	Motor and drives shipped loose
Required Accessory	Roof curb for new roof installations

**Motor Information**

Service Factor	1.5
Phase	1
Voltage	115/208-230
HP	1
Motor Enclosure	Open Drip Proof
Motor Insulation	B
Thermal Protection	AutoOverload
NEMA Frame Size	56

**Air and Sound Performance**

Motor HP	Max BHP	Max Fan RPM	Min Fan RPM	Ps (in. wg)	0	0.125	0.25	0.375	0.5	0.625	0.75	0.875	1	1.25	1.5	1.75
1	1.00	1730	1390	CFM	3,134	3,075	3,015	2,946	2,875	2,800	2,722	2,640	2,551	2,351	2,101	1,728
				Sones	26	23	22	24	24	18.2	15.2	14.2	13.4	14.2	13.9	13.9