

Centrifugal Upblast Exhaust Fan, Model CUBE-120, Belt Drive, Less Motor & Drive Package, 553-2043 CFM

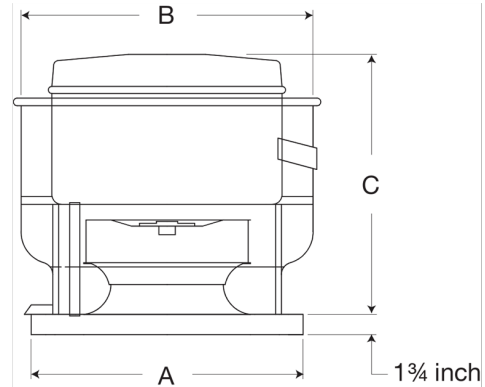

The CUBE is an aluminum exhaust fan specifically designed for roof or sidewall mounted applications where contaminated or grease laden exhaust air can be discharged directly upward, away from the roof or wall surface. The fans feature a one piece windband continuously welded to curb cap and double studded isolators for true vibration isolation.

- 19 x 19 inch base with prepunched mounting holes for easy attachment to roof curb
- Multiple motor and drive options available to meet any performance and application need
- 15.5 x 15.5 inch recommended roof opening



Certifications

AMCA Sound & Air
UL/cUL 705 Listed - Supplement SC - "Power Ventilators for Restaurant Exh. Appliances" (Formerly UL 762)

Performance Characteristics

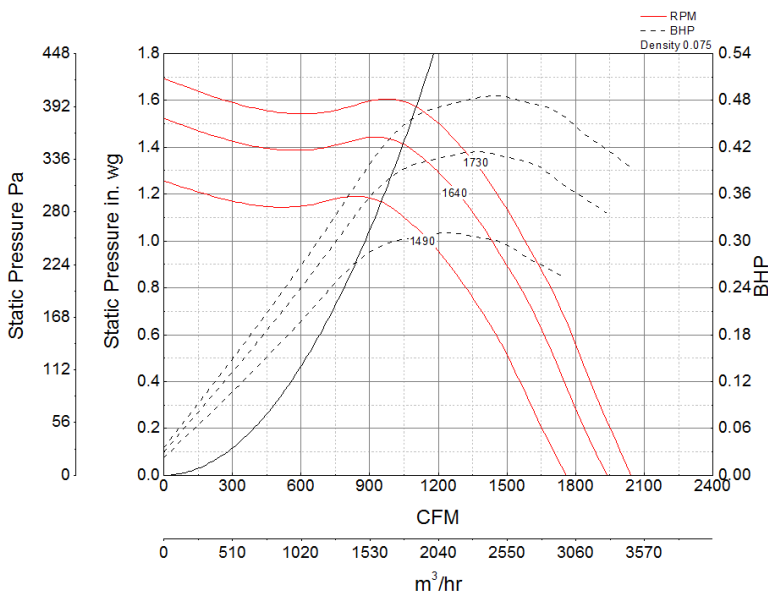

Construction Features

Drive Type	Belt Drive
Impeller Type	Centrifugal Wheel
Impeller Material	Aluminum
Housing Material	Spun Aluminum
Includes	Disconnect switch
Certifications	AMCA Sound & Air
Certifications	UL/cUL 705 Listed - Supplement SC - "Power Ventilators for Restaurant Exh. Appliances" (Formerly UL 762)
Drive Package Description	No drive package included
Required Accessory	Roof curb for new roof installations

Motor Information

Motor Included	No
----------------	----

Air and Sound Performance

Motor HP	Max BHP	Max Fan RPM	Min Fan RPM	Ps (in. wg)	0	0.125	0.25	0.375	0.5	0.625	0.75	0.875	1	1.25	1.5
1/4	0.04	770	690	CFM	909	787	626	800	1,079	955	776	1,267	1,153	1,236	1,190
				Sones	4.8	5	5.1	6.3	9.1	8.9	8.9	14	13.8	16.6	18.5
1/4	0.08	960	770	CFM	909	787	626	800	1,079	955	776	1,267	1,153	1,236	1,190
				Sones	4.8	5	5.1	6.3	9.1	8.9	8.9	14	13.8	16.6	18.5
1/4	0.16	1200	960	CFM	909	787	626	800	1,079	955	776	1,267	1,153	1,236	1,190
				Sones	4.8	5	5.1	6.3	9.1	8.9	8.9	14	13.8	16.6	18.5
1/4	0.31	1490	1200	CFM	909	787	626	800	1,079	955	776	1,267	1,153	1,236	1,190
				Sones	4.8	5	5.1	6.3	9.1	8.9	8.9	14	13.8	16.6	18.5
1/3	0.06	850	710	CFM	909	787	626	800	1,079	955	776	1,267	1,153	1,236	1,190
				Sones	4.8	5	5.1	6.3	9.1	8.9	8.9	14	13.8	16.6	18.5
1/3	0.98	1060	850	CFM	909	787	626	800	1,079	955	776	1,267	1,153	1,236	1,190
				Sones	4.8	5	5.1	6.3	9.1	8.9	8.9	14	13.8	16.6	18.5
1/3	0.21	1320	1060	CFM	909	787	626	800	1,079	955	776	1,267	1,153	1,236	1,190
				Sones	4.8	5	5.1	6.3	9.1	8.9	8.9	14	13.8	16.6	18.5
1/3	0.41	1640	1320	CFM	909	787	626	800	1,079	955	776	1,267	1,153	1,236	1,190
				Sones	4.8	5	5.1	6.3	9.1	8.9	8.9	14	13.8	16.6	18.5
1/2	0.07	900	720	CFM	909	787	626	800	1,079	955	776	1,267	1,153	1,236	1,190
				Sones	4.8	5	5.1	6.3	9.1	8.9	8.9	14	13.8	16.6	18.5
1/2	0.13	1120	900	CFM	909	787	626	800	1,079	955	776	1,267	1,153	1,236	1,190
				Sones	4.8	5	5.1	6.3	9.1	8.9	8.9	14	13.8	16.6	18.5
1/2	0.25	1390	1120	CFM	909	787	626	800	1,079	955	776	1,267	1,153	1,236	1,190
				Sones	4.8	5	5.1	6.3	9.1	8.9	8.9	14	13.8	16.6	18.5
1/2	0.48	1730	1390	CFM	909	787	626	800	1,079	955	776	1,267	1,153	1,236	1,190
				Sones	4.8	5	5.1	6.3	9.1	8.9	8.9	14	13.8	16.6	18.5