

Sidewall Propeller Exhaust Fan, Model SE1-16, Direct Drive, 1/2HP, 115/208-230V, 1Ph, 1666-3373 CFM

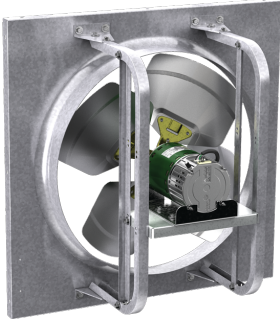

Model SE1, direct drive, sidewall propeller exhaust fans provide general ventilation in commercial and industrial applications. Units feature corrosion resistant aluminum propellers and are ideal for quietly exhausting air in schools, storage facilities, and manufacturing and assembly areas.

- 24 x 24 inch fan panel with prepunched mounting holes for easy installation and precise alignment
- Speed controllable, with up to 30% turndown
- 16 inch aluminum propeller offering superior corrosion resistance

Certifications

AMCA Sound & Air
UL/cUL 705

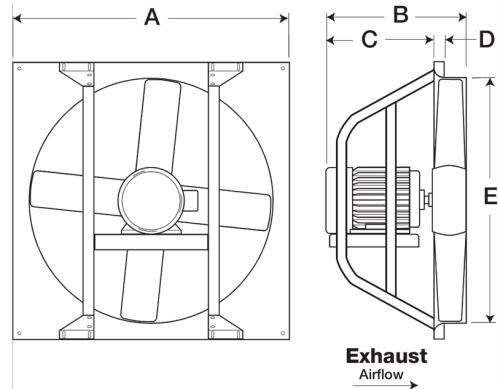

Performance Characteristics

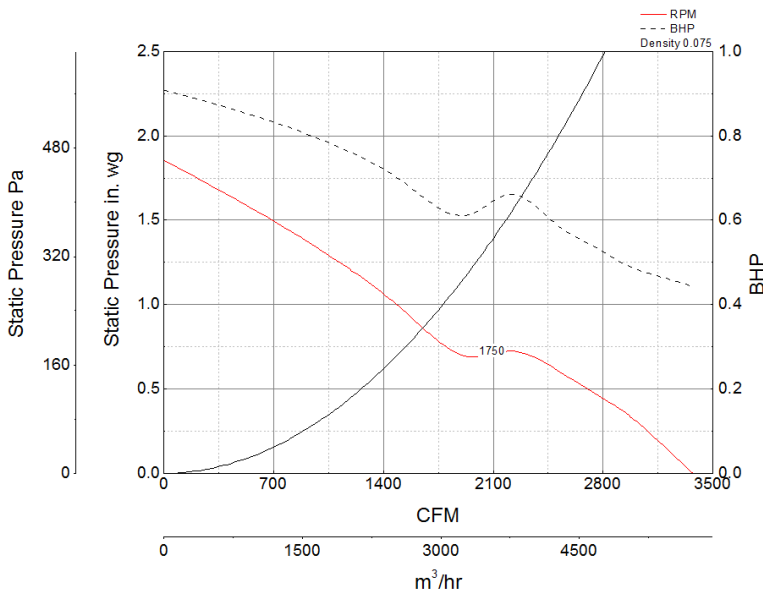

Construction Features

Drive Type	Direct Drive
Impeller Type	Propeller
Impeller Material	Aluminum
Housing Material	Galvanized Steel
Certifications	AMCA Sound & Air
Certifications	UL/cUL 705
Speed Controllable	Yes

Motor Information

Service Factor	1
Phase	1
Voltage	115/230
HP	1/2
Motor Enclosure	Open Drip Proof
Motor Insulation	B

Thermal Protection	AutoOverload
--------------------	--------------

Air and Sound Performance

Motor HP	Max BHP	Max Fan RPM	Min Fan RPM	Ps (in. wg)	0	0.125	0.25	0.375	0.5	0.75	0.875	1
1/2	0.66	1750	0	CFM	3,373	3,228	3,079	2,908	2,701	2,468	1,862	1,666
				Sones	15.3	14.7	14.8	14.7	15.3	16.6	14.8	14.2



- Greenheck Fan Corporation certifies that the model shown herein is licensed to bear the AMCA seal. The ratings shown are based on tests and procedures performed in accordance with AMCA Publication 211 and AMCA Publication 311 and comply with the requirements of the AMCA Certified Ratings Program.
- Performance certified is for installation type A: Free inlet, Free outlet.
- Power rating (Bhp/kW) does not include transmission losses.
- Performance ratings do not include the effects of appurtenances (accessories).
- The sound ratings shown are loudness values in fan sones at 5 ft. (1.5 m) in a hemispherical free field calculated per AMCA Standard 301. Values shown are for installation type A: free inlet hemispherical sone levels.