

Centrifugal Downblast Exhaust Fan, Product # GB-160-5122X3QD-DR2, 1421-2658 CFM



Model GB, belt drive centrifugal roof exhaust fans are designed to meet the general clean air exhaust requirements for industrial and commercial buildings. Units feature a fully rolled windband bead for increased stability and easy transport. Fresh outside air is drawn in under the motor cover to maximize motor life.

- 22 x 22 inch base with prepunched mounting holes for easy attachment to roof curb
- Variable pitch adjustable motor pulley to optimize fan performance
- 18.5 x 18.5 inch recommended roof opening

Certifications

AMCA Sound & Air
High Wind and Hurricane
Seismic
UL/cUL 705



Performance Characteristics

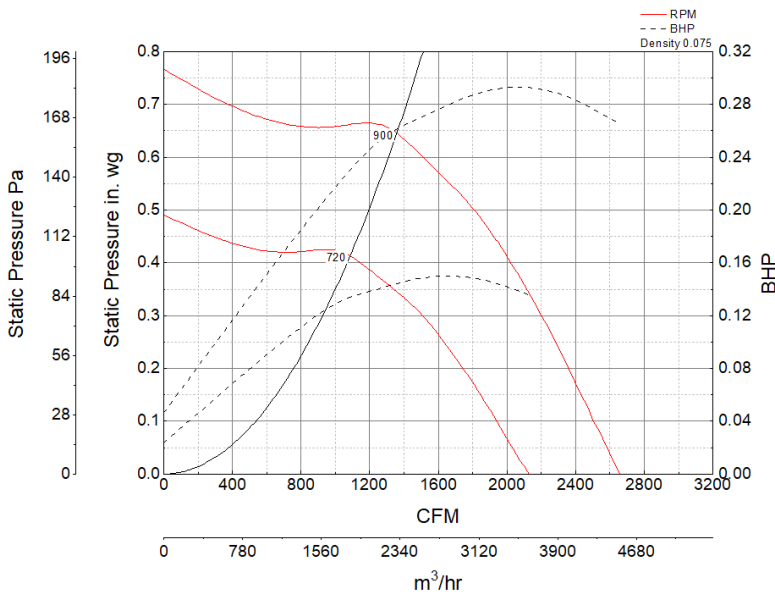

Construction Features

Drive Type	Belt Drive
Impeller Type	Centrifugal Wheel
Impeller Material	Aluminum
Housing Material	Spun Aluminum
Includes	Unassembled drive package
Certifications	AMCA Sound & Air
Certifications	High Wind and Hurricane
Certifications	Seismic
Certifications	UL/cUL 705
Drive Package Description	Motor and drives shipped loose
Required Accessory	Roof curb for new installations

Motor Information

Service Factor	1.25
Phase	3
Voltage	208-230/460
HP	1/2
Motor Enclosure	Open Drip Proof
Motor Insulation	F
NEMA Frame Size	56

Air and Sound Performance

Motor HP	Max BHP	Max Fan RPM	Min Fan RPM	Ps (in. wg)	0	0.125	0.25	0.375	0.5	0.625
1/2	0.29	900	720	CFM	2,658	2,471	2,282	2,069	1,803	1,421
				Sones	11.6	11	10.6	10.2	9.6	8.9