

Sidewall Propeller Exhaust Fan, Model SBE-2L36, Belt Drive, 3HP, 208-230/460V, 3Ph, Motor & Drives Unassembled, 12082-20194 CFM

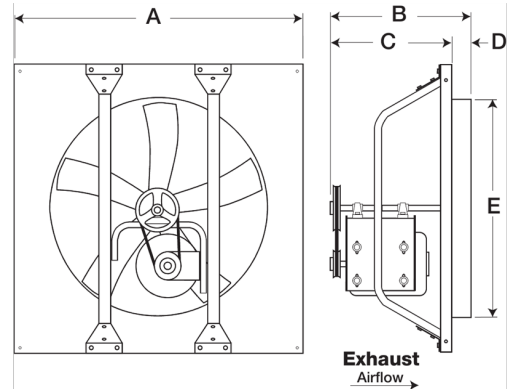

- Model SBE, belt drive, sidewall propeller exhaust fans are designed for commercial and industrial applications where high volumes of air and low static pressures are required.
- 42 x 42 inch fan panel with prepunched mounting holes for easy installation and precise alignment
 - 36 inch, 5-blade galvanized steel propeller
 - Adjustable motor pulley to optimize fan performance

Certifications
AMCA Sound & Air
UL/cUL 705



Performance Characteristics

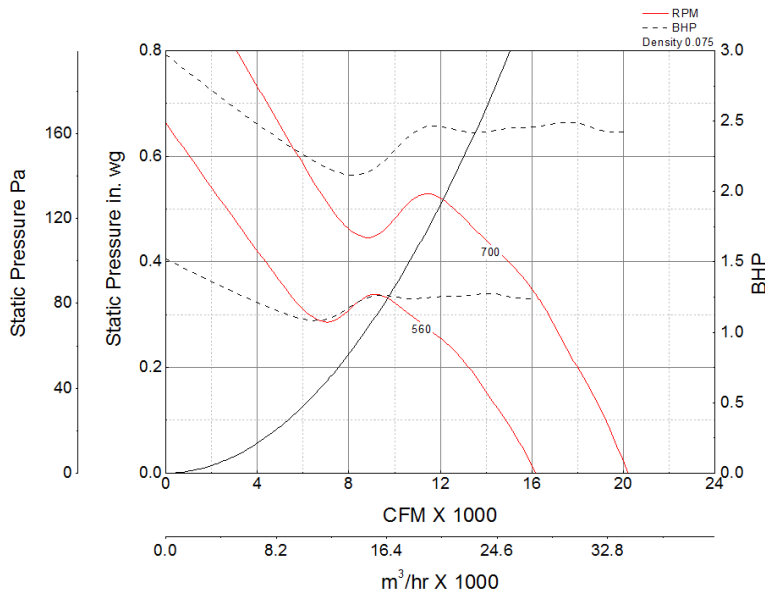

Construction Features

Drive Type	Belt Drive
Impeller Type	Propeller
Impeller Material	Galvanized Steel
Housing Material	Galvanized Steel
Includes	Unassembled drive package
Certifications	AMCA Sound & Air
Certifications	UL/cUL 705
Drive Package Description	Motor and drives shipped loose

Motor Information

Service Factor	1.15
Phase	3
Voltage	208-230/460
HP	3
Motor Enclosure	Open Drip Proof
Motor Insulation	F
NEMA Frame Size	182T

Air and Sound Performance

Motor HP	Max BHP	Max Fan RPM	Min Fan RPM	Ps (in. wg)	0	0.125	0.25	0.375	0.5
3	2.48	700	560	CFM	20,194	18,965	17,344	15,450	12,082
				Sones	28	27	26	26	25



- Greenheck Fan Corporation certifies that the model shown herein is licensed to bear the AMCA seal. The ratings shown are based on tests and procedures performed in accordance with AMCA Publication 211 and AMCA Publication 311 and comply with the requirements of the AMCA Certified Ratings Program.
- Performance certified is for installation type A: Free inlet, Free outlet.
- Power rating (Bhp/kW) includes transmission losses.
- Performance ratings do not include the effects of appurtenances (accessories).
- The sound ratings shown are loudness values in fan sones at 5 ft. (1.5 m) in a hemispherical free field calculated per AMCA Standard 301. Values shown are for installation type A: free inlet hemispherical sone levels.