

# Sidewall Propeller Exhaust Fan, Model SBE-2L30, Belt Drive, 1 1/2HP, 115/208-230V, 1Ph, Motor & Drives Unassembled, 10353-13734 CFM

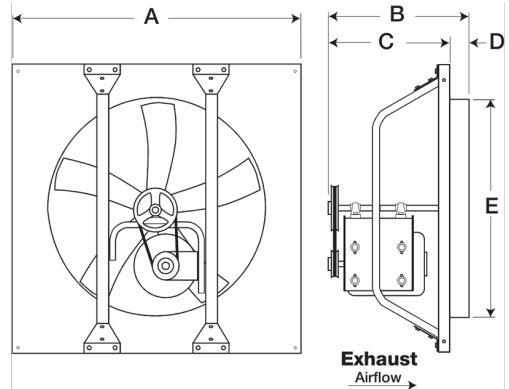

- Model SBE, belt drive, sidewall propeller exhaust fans are designed for commercial and industrial applications where high volumes of air and low static pressures are required.
- 38 x 38 inch fan panel with prepunched mounting holes for easy installation and precise alignment
  - 30 inch, 5-blade galvanized steel propeller
  - Adjustable motor pulley to optimize fan performance

**Certifications**  
AMCA Sound & Air  
UL/cUL 705



## Performance Characteristics

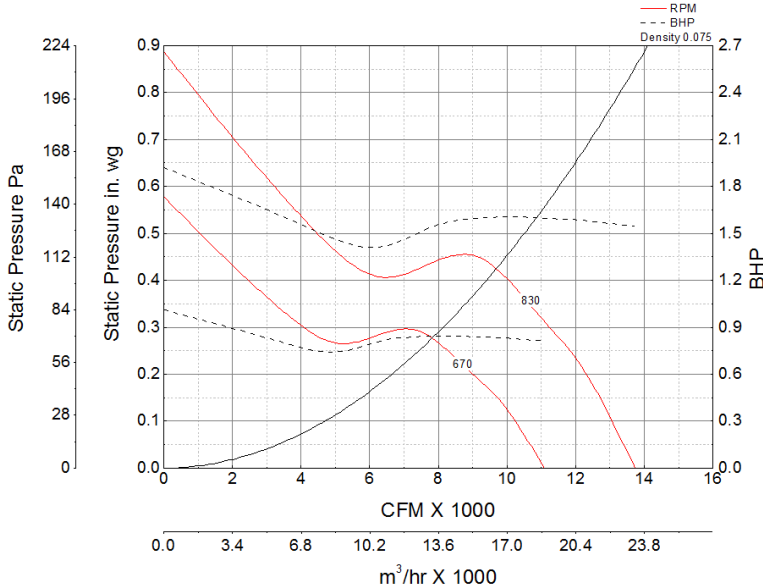

## Construction Features

Drive Type	Belt Drive
Impeller Type	Propeller
Impeller Material	Galvanized Steel
Housing Material	Galvanized Steel
Includes	Unassembled drive package
Certifications	AMCA Sound & Air
Certifications	UL/cUL 705

Drive Package Description: Motor and drives shipped loose

## Motor Information

Phase	1
Voltage	115/208-230
HP	1 1/2
Motor Enclosure	Open Drip Proof
Motor Insulation	B

Thermal Protection: AutoOverload

## Air and Sound Performance

Motor HP	Max BHP	Max Fan RPM	Min Fan RPM	Ps (in. wg)	0	0.125	0.25	0.375
1 1/2	1.60	830	670	CFM	13,734	12,893	11,808	10,353
				Sones	25	24	24	23



- Greenheck Fan Corporation certifies that the model shown herein is licensed to bear the AMCA seal. The ratings shown are based on tests and procedures performed in accordance with AMCA Publication 211 and AMCA Publication 311 and comply with the requirements of the AMCA Certified Ratings Program.
- Performance certified is for installation type A: Free inlet, Free outlet.
- Power rating (Bhp/kW) includes transmission losses.
- Performance ratings do not include the effects of appurtenances (accessories).
- The sound ratings shown are loudness values in fan sones at 5 ft. (1.5 m) in a hemispherical free field calculated per AMCA Standard 301. Values shown are for installation type A: free inlet hemispherical sone levels.