

# Sidewall Propeller Exhaust Fan, Model SBE-2L36, Belt Drive, Less Motor & Drive Package, 9995-20194 CFM



Model SBE, belt drive, sidewall propeller exhaust fans are designed for commercial and industrial applications where high volumes of air and low static pressures are required.

- 42 x 42 inch fan panel with prepunched mounting holes for easy installation and precise alignment
- 36 inch, 5-blade galvanized steel propeller
- Multiple motor and drive options available to meet any performance and application need

**Certifications**  
AMCA Sound & Air  
UL/cUL 705

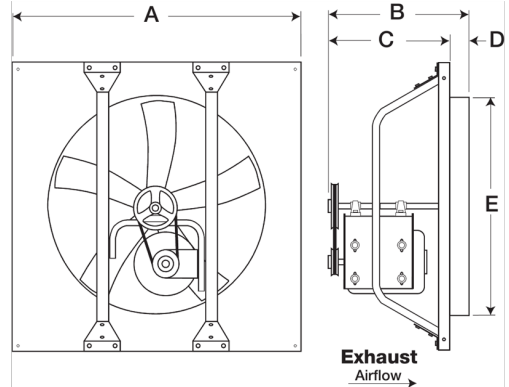

## Performance Characteristics

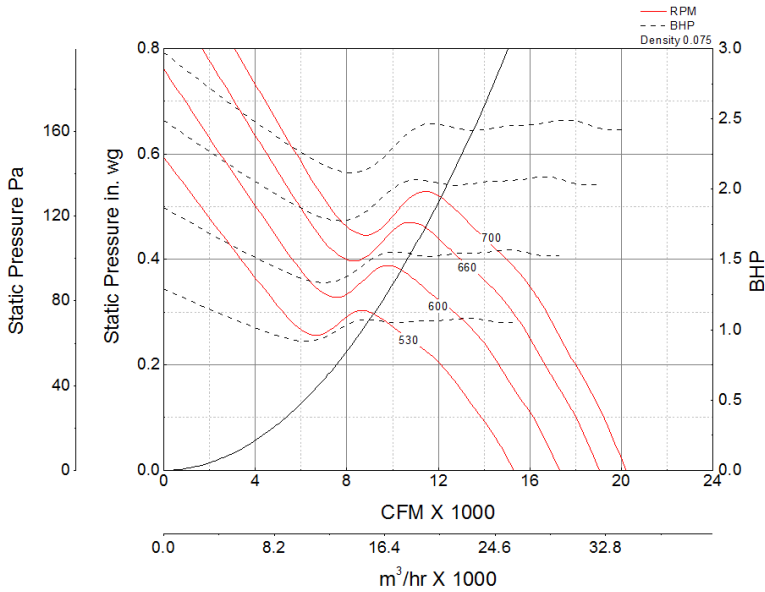

## Construction Features

Drive Type	Belt Drive
Impeller Type	Propeller
Impeller Material	Galvanized Steel
Housing Material	Galvanized Steel
Certifications	AMCA Sound & Air
Certifications	UL/cUL 705
Drive Package Description	No drive package included

## Motor Information

Motor Included	No
----------------	----

## Air and Sound Performance

Motor HP	Max BHP	Max Fan RPM	Min Fan RPM	Ps (in. wg)	0	0.125	0.25	0.375	0.5
1	0.57	430	370	CFM	12,405	9,995	10,690	13,635	12,082
				Sones	13.3	13.1	15.5	23	25
1	1.08	530	430	CFM	12,405	9,995	10,690	13,635	12,082
				Sones	13.3	13.1	15.5	23	25
1 1/2	0.80	480	450	CFM	12,405	9,995	10,690	13,635	12,082
				Sones	13.3	13.1	15.5	23	25
1 1/2	1.55	600	480	CFM	12,405	9,995	10,690	13,635	12,082
				Sones	13.3	13.1	15.5	23	25
2	2.07	660	530	CFM	12,405	9,995	10,690	13,635	12,082
				Sones	13.3	13.1	15.5	23	25
3	2.48	700	560	CFM	12,405	9,995	10,690	13,635	12,082
				Sones	13.3	13.1	15.5	23	25



- Greenheck Fan Corporation certifies that the model shown herein is licensed to bear the AMCA seal. The ratings shown are based on tests and procedures performed in accordance with AMCA Publication 211 and AMCA Publication 311 and comply with the requirements of the AMCA Certified Ratings Program.
- Performance certified is for installation type A: Free inlet, Free outlet.
- Power rating (Bhp/kW) includes transmission losses.
- Performance ratings do not include the effects of appurtenances (accessories).
- The sound ratings shown are loudness values in fan sones at 5 ft. (1.5 m) in a hemispherical free field calculated per AMCA Standard 301. Values shown are for installation type A: free inlet hemispherical sone levels.