

## Square Centrifugal Inline Fan, Product # BSQ-180-7X-3-QD-DR1, 2289-3527 CFM



Model BSQ centrifugal inline fan features a unique combination of installation flexibility, rugged construction, ease of service, high efficiency and low sound levels. These compact fans are the ideal selection for indoor clean air applications including intake, exhaust, return or make-up air.

- 23.875 x 23.875 inch inlet width x height
- 23.875 x 23.875 inch outlet width x height
- Horizontal or vertical mounting

### Certifications

AMCA Sound & Air  
UL/cUL 705

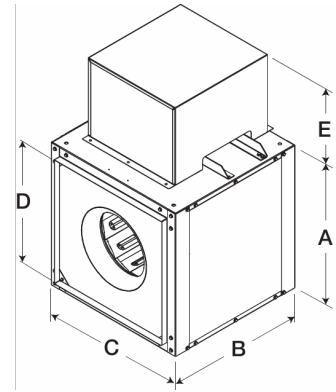

### Performance Characteristics

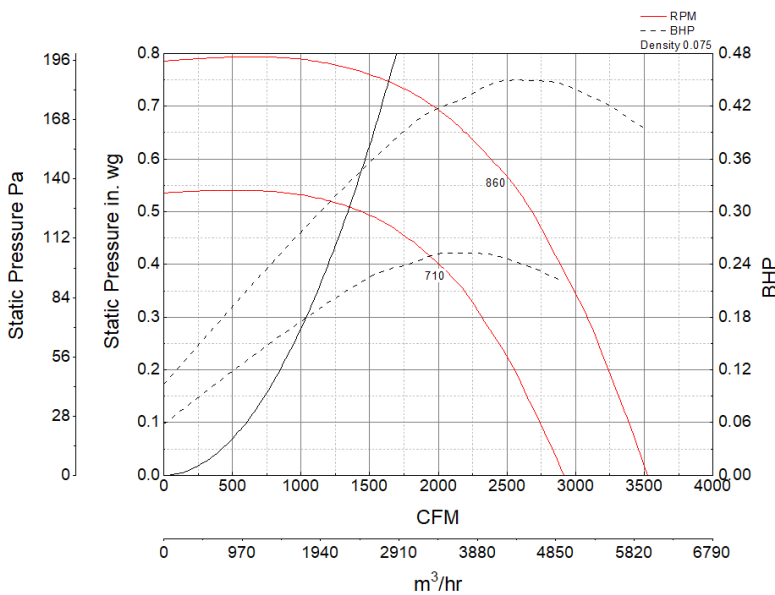

### Construction Features

Drive Type	Belt Drive
Impeller Type	Centrifugal Wheel
Impeller Material	Aluminum
Housing Material	Galvanized Steel
Includes	Motor cover
Includes	Unassembled drive package
Certifications	AMCA Sound & Air
Certifications	UL/cUL 705
Drive Package Description	Motor and drives shipped loose

### Motor Information

Service Factor	1.25
Phase	3
Voltage	208-230/460
HP	3/4
Motor Enclosure	Open Drip Proof
Motor Insulation	F
NEMA Frame Size	56

### Air and Sound Performance

Motor HP	Max BHP	Max Fan RPM	Min Fan RPM	Ps (in. wg)	0	0.125	0.25	0.375	0.5	0.625
3/4	0.45	860	710	CFM	3,527	3,352	3,162	2,938	2,682	2,289
				Sones	11.6	11.7	11.7	11.4	11.1	10.4



- Greenheck Fan Corporation certifies that the model shown herein is licensed to bear the AMCA Seal. The ratings shown are based on tests and procedures performed in accordance with AMCA Publication 211 and AMCA Publication 311 and comply with the requirements of the AMCA Certified Ratings Program.
- Performance certified is for installation type B: Free inlet, Ducted outlet.
- Power rating (BHP/kW) includes transmission losses.
- Performance ratings do not include the effects of appurtenances (accessories).
- The inlet sound ratings shown are loudness values in fan sones at 5 ft. (1.5 m) in a hemispherical free field calculated per AMCA Standard 301. Values shown are for installation type B: free inlet hemispherical sone levels.