

Centrifugal Downblast Exhaust Fan, Product # GB-160-3122XQD-DR1, 1292-1890 CFM

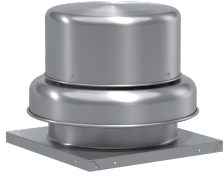

Model GB, belt drive centrifugal roof exhaust fans are designed to meet the general clean air exhaust requirements for industrial and commercial buildings. Units feature a fully rolled windband bead for increased stability and easy transport. Fresh outside air is drawn in under the motor cover to maximize motor life.

- 22 x 22 inch base with prepunched mounting holes for easy attachment to roof curb
- Variable pitch adjustable motor pulley to optimize fan performance
- 18.5 x 18.5 inch recommended roof opening

Certifications

AMCA Sound & Air
High Wind and Hurricane
Seismic
UL/cUL 705



Performance Characteristics

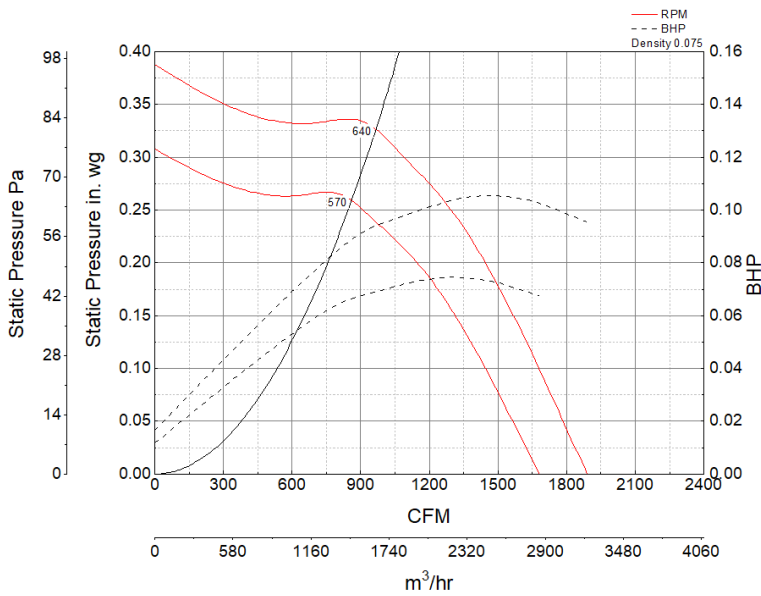

Construction Features

Drive Type	Belt Drive
Impeller Type	Centrifugal Wheel
Impeller Material	Aluminum
Housing Material	Spun Aluminum
Includes	Unassembled drive package
Certifications	AMCA Sound & Air
Certifications	High Wind and Hurricane
Certifications	Seismic
Certifications	UL/cUL 705
Drive Package Description	Motor and drives shipped loose
Required Accessory	Roof curb for new installations

Motor Information

Service Factor	1.35
Phase	1
Voltage	115/208-230
HP	1/3
Motor Enclosure	Open Drip Proof
Motor Insulation	B
Thermal Protection	AutoOverload
NEMA Frame Size	48

Air and Sound Performance

Motor HP	Max BHP	Max Fan RPM	Min Fan RPM	Ps (in. wg)	0	0.125	0.25
1/3	0.10	640	570	CFM	1,890	1,626	1,292
				Sones	6.6	6.4	6.1