

Centrifugal Inline Fan, Model SQ-95, Direct Drive, 3-Speed, 115V, 1Ph, 275-920 CFM

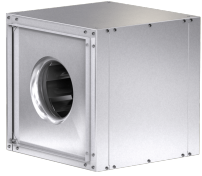

Model SQ, direct drive centrifugal inline fans feature a unique combination of installation flexibility, rugged construction, ease of service, high efficiency and low sound levels. These compact fans are ideal for indoor clean air applications including exhaust, return or make-up where space is a prime consideration.

- Compact size for height-restricted areas
- Composite backward inclined, non-overloading centrifugal wheel design
- Inlet and discharge duct collars for easy duct connection
- Removable access panels permit easy access to interior components for cleaning and servicing.

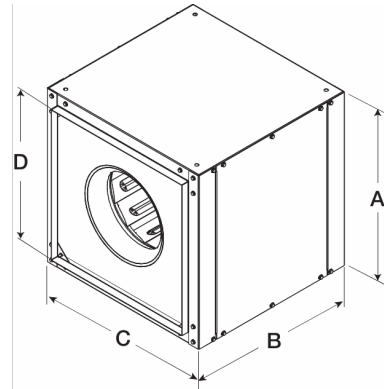

Certifications

AMCA Sound & Air Performance
UL/cUL 705

Performance Characteristics

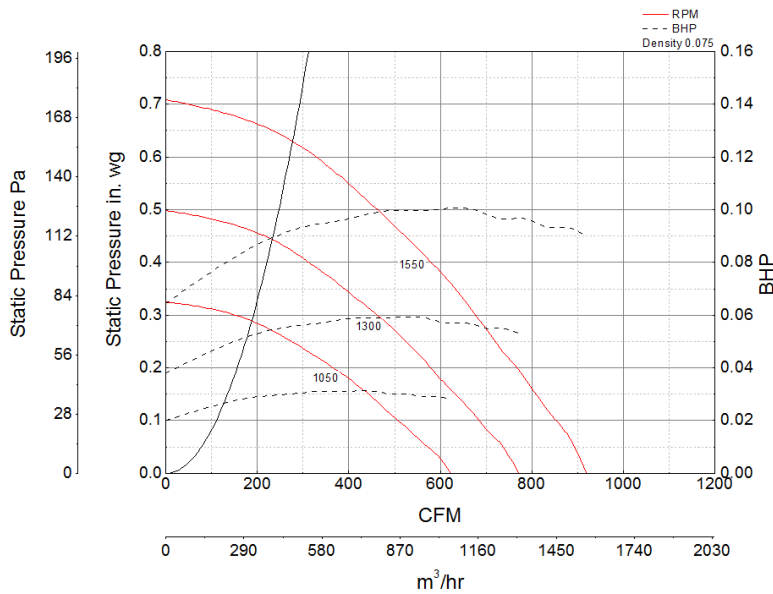

Construction Features

Drive Type	Direct Drive
Impeller Type	Centrifugal Wheel
Impeller Material	Aluminum
Housing Material	Galvanized Steel
Includes	Access Panel
Includes	Disconnect switch
Certifications	AMCA Sound & Air Performance
Certifications	UL/cUL 705
Speed Controllable	Yes

Motor Information

Service Factor	1
Phase	1
Voltage	115
HP	1/8
Motor Enclosure	n/a
Motor Insulation	B
Thermal Protection	AutoOverload

Watts 92.6

Air and Sound Performance

Motor HP	Max BHP	Max Fan RPM	Min Fan RPM	Ps (in. wg)	0	0.125	0.25	0.375	0.5	0.625
1/8	0.03	1050	0	CFM	623	475	275	352	462	276
				Sones	4.9	4.5	4.5	6.4	8.1	8.1
1/8	0.06	1300	0	CFM	623	475	275	352	462	276
				Sones	4.9	4.5	4.5	6.4	8.1	8.1
1/8	0.10	1550	0	CFM	623	475	275	352	462	276
				Sones	4.9	4.5	4.5	6.4	8.1	8.1



- Greenheck Fan Corporation certifies that the model shown herein is licensed to bear the AMCA Seal. The ratings shown are based on tests and procedures performed in accordance with AMCA Publication 211 and AMCA Publication 311 and comply with the requirements of the AMCA Certified Ratings Program.
- Performance certified is for installation type B: Free inlet, Ducted outlet.
- Power rating (BHP/kW) does not include transmission losses.
- Performance ratings do not include the effects of appurtenances (accessories).
- The inlet sound ratings shown are loudness values in fan sones at 5 ft. (1.5 m) in a hemispherical free field calculated per AMCA Standard 301. Values shown are for installation type B: free inlet hemispherical sone levels.