

Ceiling Fan Model SPB-50 50 CFM 120-1



Low profile bathroom exhaust fan, Model SP-B features a forward-curved wheel for low sound and high efficiency. Units are ideal for residential, multi-family or hotel applications.

- Compact size for height restricted areas
- Round standard outlet for quick, easy connections
- Integral damper prevents unwanted backdrafts
- Speed controllable
- Designer grille included

Certifications

AMCA Air &Sound
UL/cUL 507

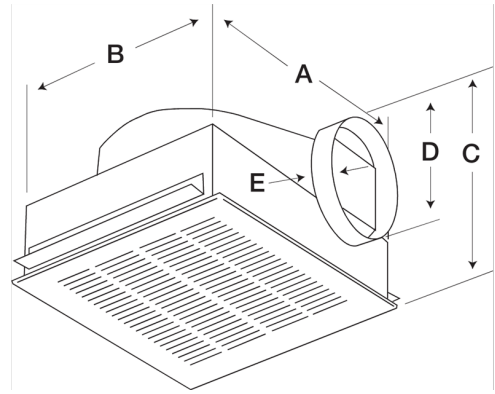

Performance Characteristics

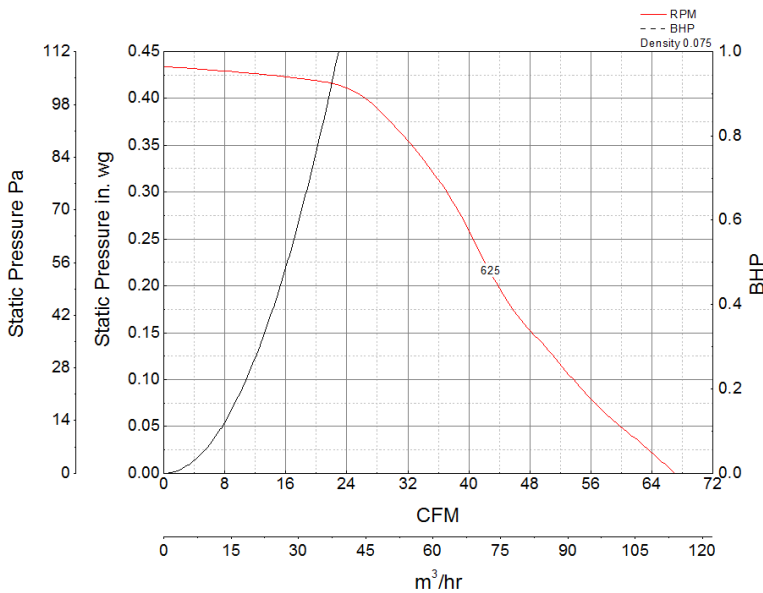

Construction Features

Drive Type	Direct Drive
Impeller Type	Centrifugal Wheel
Impeller Material	Polypropylene
Housing Material	Galvanized Steel
Includes	Backdraft damper
Includes	Mounting brackets
Certifications	AMCA Air &Sound
Certifications	UL/cUL 507
Speed Controllable	Yes

Motor Information

Service Factor	0
Phase	1
Voltage	115
Motor Enclosure	n/a
Motor Insulation	B
Thermal Protection	AutoOverload
Watts	15

Air and Sound Performance

Watts	Max Fan RPM	Min Fan RPM	Ps (in. wg)	0	0.125	0.25	0.375
37.8	625	500	CFM	67	51	40	29
			Sones	1.2	1.4	2	3