

## Ceiling Fan Model SPB-90 90 CFM 120-1



Low profile bathroom exhaust fan, Model SP-B features a forward-curved wheel for low sound and high efficiency. Units are ideal for residential, multi-family or hotel applications.

- ENERGY STAR rated
- Compact size for height restricted areas
- Round standard outlet for quick, easy connections
- Integral damper prevents unwanted backdrafts
- Speed controllable
- Designer grille included

### Certifications

AMCA Air &Sound  
UL/cUL 507

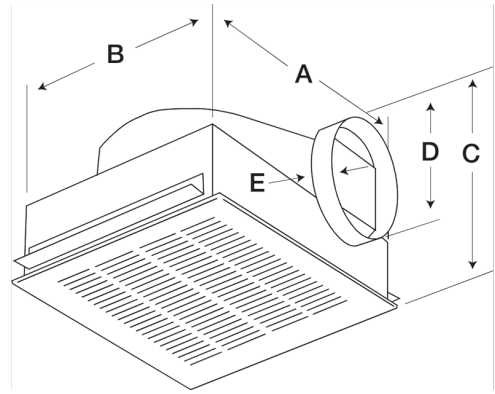

### Performance Characteristics

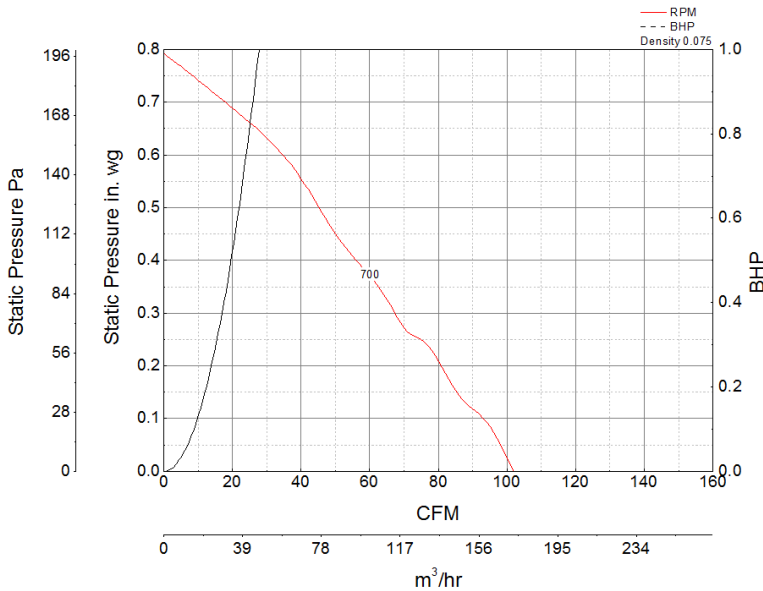

### Construction Features

Drive Type	Direct Drive
Impeller Type	Centrifugal Wheel
Impeller Material	Polypropylene
Housing Material	Galvanized Steel
Includes	Backdraft damper
Includes	Mounting brackets
Certifications	AMCA Air &Sound
Certifications	UL/cUL 507
Speed Controllable	Yes

### Motor Information

Service Factor	1
Phase	1
Voltage	115
Motor Enclosure	n/a
Motor Insulation	B

Watts 5

### Air and Sound Performance

Watts	Max Fan RPM	Min Fan RPM	Ps (in. wg)	0	0.125	0.25	0.375
21.1	700	560	CFM	104	89	72	57
			Sones	1	1	1.5	2