

Extruded Aluminum Brick Vent, 15 In X 7 In



Brick vents provide a permanent means of ventilation for crawl spaces, hung ceilings, incinerator rooms, chimney flues, foundations, pipe spaces and corridors. Extruded construction provides a quality finished appearance. A high water stop at the rear and deep overlapping blades with storm stops provide maximum resistance to rain and weather.

- Anodized aluminum construction
- Built in aluminum mesh insect screen

Certifications

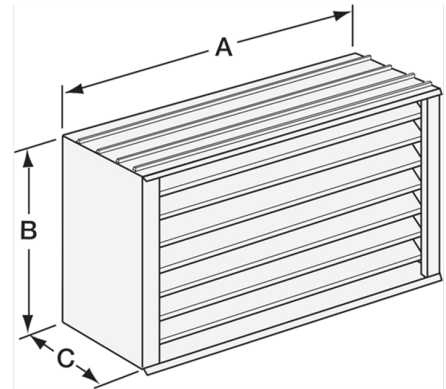

Performance Characteristics

No Fan Curve Available.

Construction Features

Frame Material	Heavy gauge extruded 6063T5 aluminum
Frame Type	No Flange
Blade Material	Heavy gauge extruded 6063T5 aluminum