

## Centrifugal Downblast Exhaust Fan, Product # GB-140-10122X3QD-DR2, 1836-3209 CFM

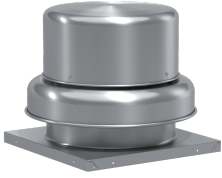

Model GB, belt drive centrifugal roof exhaust fans are designed to meet the general clean air exhaust requirements for industrial and commercial buildings. Units feature a fully rolled windband bead for increased stability and easy transport. Fresh outside air is drawn in under the motor cover to maximize motor life.

- 22 x 22 inch base with prepunched mounting holes for easy attachment to roof curb
- Variable pitch adjustable motor pulley to optimize fan performance
- 18.5 x 18.5 inch recommended roof opening

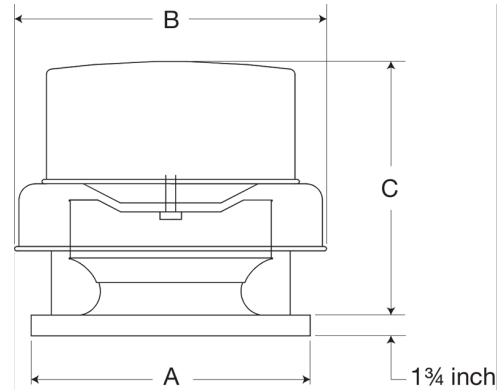

### Certifications

Seismic  
AMCA Sound & Air  
High Wind and Hurricane  
UL/cUL 705

### Performance Characteristics

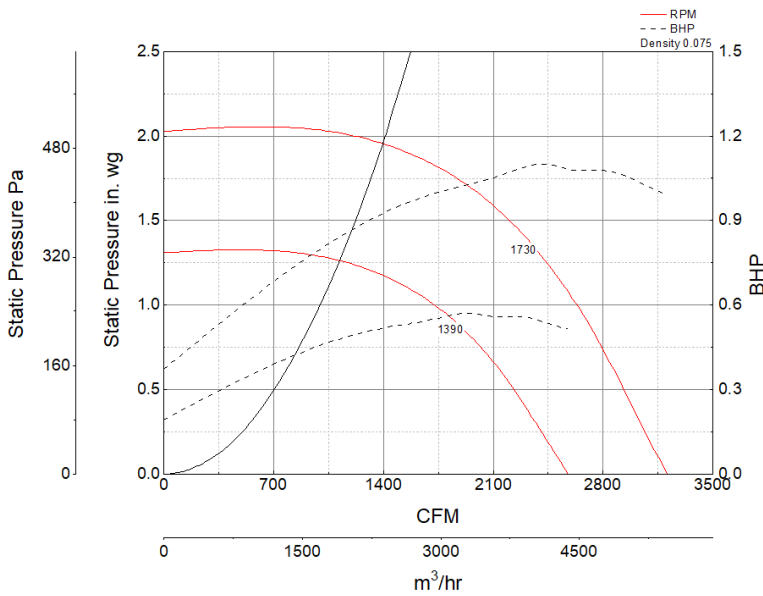

### Construction Features

Drive Type	Belt Drive
Impeller Type	Centrifugal Wheel
Impeller Material	Aluminum
Housing Material	Spun Aluminum
Includes	Unassembled drive package
Certifications	Seismic
Certifications	AMCA Sound & Air
Certifications	High Wind and Hurricane
Certifications	UL/cUL 705
Drive Package Description	Motor and drives shipped loose
Required Accessory	Roof curb for new installations

### Motor Information

Service Factor	1.15
Phase	3
Voltage	208-230/460
HP	1
Motor Enclosure	Open Drip Proof
Motor Insulation	F
NEMA Frame Size	56

### Air and Sound Performance

Motor HP	Max BHP	Max Fan RPM	Min Fan RPM	Ps (in. wg)	0	0.125	0.25	0.375	0.5	0.625	0.75	0.875	1	1.25	1.5	1.75
					CFM	3,209	3,139	3,069	3,001	2,934	2,863	2,792	2,713	2,631	2,441	2,199
1	1.10	1730	1390	Sones	21	21	20	20	19.7	19.3	18.5	17.7	17.3	17	16.9	16.7